

ALLEN & HEATH

ALL RANGES

**LARGE FORMAT
LIVE SOUND MIXERS**

**SMALL FORMAT
LIVE SOUND MIXERS**

DJ PRODUCTS

**SOUND MANAGEMENT
SYSTEMS**

**SOUND MANAGEMENT
SYSTEMS**

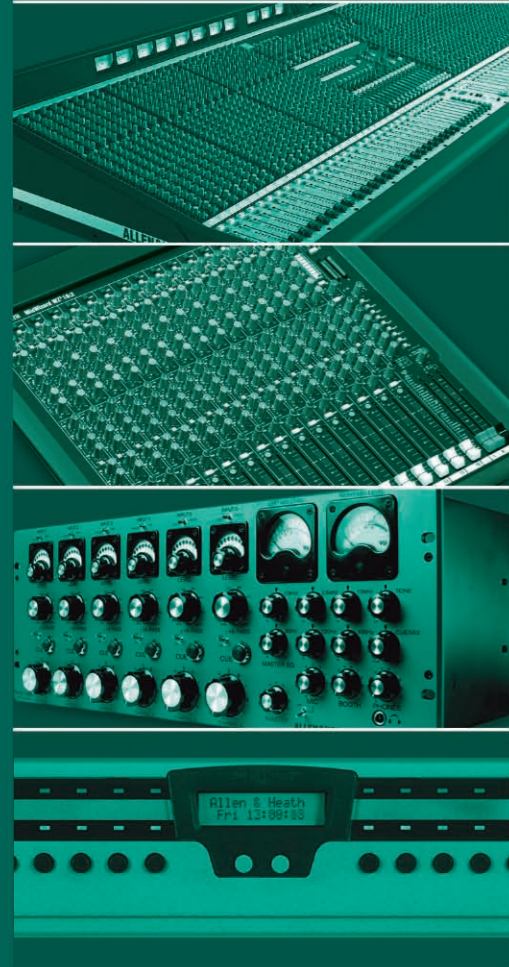

ALLEN & HEATH

Kernick Industrial Estate
Penryn · Cornwall
TR10 9LU · UK

tel: +44 (0)1326 372070
fax: +44 (0)1326 377097

email:
sales@allen-heath.com
website:
www.allen-heath.com
www.idrseries.com

Allen & Heath reserve the right to alter any
information supplied in this document or any
other documentation supplied hereafter.

AP5909

Training courses for **iDR** system building
available worldwide.

Check www.idrseries.com for details or email
training@allen-heath.com



ALLEN & HEATH

iDR SERIES WHAT IS IT?



The **iDR** is a **16 x 16 matrix mixer** with an extensive array of audio management tools designed to reduce the need for additional devices to be specified for an installation, or carried in the hire inventory. Pedigree **ALLEN&HEATH** preamps, 24bit converters and fixed DSP architecture ensure that concert-quality low-latency sound is delivered efficiently to where it is needed.

Anyone with a basic knowledge of traditional console and outboard equipment will be able to design a distributed audio system on their PC using the 'mixer' based **iDR System Manager** software - download it free from www.idrseries.com.

iDR comes loaded with flexible DSP tools, essential in sound system configuration and installation. Input & output delays, 4- and 8-band parametric EQ, automatic microphone mixing, frequency conscious dynamics, look-ahead limiter, ambient noise compensator, crossfader and much more are available at your fingertips without having to worry about running out of DSP. Its system of presets allow for full recall of the whole system or individual parameters at the touch of a button.

After programming, the **iDR** unit operates as a stand-alone system controller, with a host of remote control devices available for day-to-day operation. The **PL** Series complements the powerful features of **iDR** and comprises wall plates, infra-red hand-held or desk mount controllers connecting to the main unit using CAT5 cable over the RS485-based proprietary **PL-Anet** bus, while all the major third party devices may also be used to control **iDR**.

For complex systems, the **iDR** system can be driven in real time by a PC via an Ethernet port, allowing the **iDR** to be used in hire/live audio situations such as matrix distribution in theatres, or clean feed system for an outside broadcast. Why not connect a WiFi card to your laptop, connect to the internet, set up your system and save your settings on the move? Stay in control from anywhere in the world!

iDR SERIES WHY IS IT SO USEFUL?

Network control



The main **iDR** units can be easily controlled and programmed with an Ethernet connection to a PC [or MAC running OSX & PC simulator]. All **iDR** units on a network can be 'seen', by more than one computer, with optional password protection so that operators can be observed by a technician running **iDR System Manager** software - or PL Client software - anywhere on the network or World Wide Web. **iDR** can even output a log of its activities to an email address!

Proprietary TCP/IP devices such as 'WiFi', can be used for cost effective and practical uses; for example, a 'wireless laptop', can be used to commission or update the sound system from exactly where the technician needs to monitor it.

Preset System



iDR provides a system of up to 250 presets for total recall of system settings. A preset can contain the settings for all system devices, e.g. a default preset to set the entire system on power-up, or individual devices can be selected for exclusive change in a preset, e.g. a single EQ or fader gain level. A recall crossfader is provided to fade between different preset levels. Scheduled preset recalls are available, timed from the **iDR** internal clock. Preset recalls can be triggered from **ALLEN&HEATH** equipment (**PL** controllers other **iDR**'s or **iDR-Switch**) or via the serial, MIDI and Telnet ports using third party equipment.

PL-Anet



The **PL** Series is the perfect interface between the **iDR** and the operators on site, providing simple, non-technical switch, indicator display, fader, IR and encoder control options. Furthermore, as the requirements grow at an installation, the control system can too.

PL remotes can simply daisy chain or use the '**PL-Anet**' hub for star wiring applications, and all cabling is CAT5. You as the designer can customize these 'plug-n-play' remotes to do exactly what the customer needs. Each **PL** has its own simulator in **iDR System Manager** software, so you can design and demo the system offline as it will appear when the hardware is in place.

Automatic Level Management



iDR is equipped with several powerful modules to manage a distributed sound system, so an operator or technician doesn't always need to be present. For instance:

- ★ Microphones in a conference situation can be controlled by any one of the four on-board **AMM**'s, so that as more open microphones join in, the gain of the sum is reduced to prevent feedback occurring.
- ★ A comprehensive **Ducking** system is provided with adjustable priorities.
- ★ Ambient Noise Compensator (**ANC**) enables the output level in a zone to be automatically managed in relation to the signal level of the changing background noise level
- ★ **Level Sensing** provides a logic or soft LED output when a pre-set signal threshold is reached, which triggers indicators and other hardware to respond; this allows operations such as camera following.
- ★ 2 independent **paging** systems are provided, with paging to selectable outputs. Paging switches and indicators can be triggered via **A&H** controllers; alternatively, custom paging panels can be created and interfaced with the system.

Expandability



As the system requirements grow, additional **iDR** units or expanders can be added to suit the budget and application. **iDR-8** and **iDR-4** have 8-buss digital expansion ports (RJ45) to allow units to be daisy-chained together, or to add an **iDR-In** or **iDR-Out** 8-channel expander.

The CAT5 cables allow the units to be placed at distances up to 250m apart, allowing, for example, the **iDR-In** to provide 8 XLR mic/line inputs in a function room on a different floor to the control room containing the main **iDR** unit, or, similarly, the **iDR-Out** could be configured as a four-way-stereo XLR output to an amp rack located at the side of a theatre stage.

Furthermore, the 8-buss link can be used to distribute signals around a complex network where **iDR** units communicate via TCP/IP - here, interbox paging and routing is possible.

Audio Quality



Low latency [2.23ms from input to output] and a fixed DSP architecture ensures that the **iDR** system will distribute coherent audio no matter how many modules of DSP are used in the system.

Mic preamp gain is controlled in analogue under software control so levels can be optimised in real time if needed. **iDR-8** has a hardware limiter before the A-D converter so that the contractor can have confidence in the signal integrity, even if input levels exceed what was expected.

Signal Processing



The **iDR-4** & **iDR-8** signal processing architectures provide 16 channels of input processing and 16 channels of output processing, centred around the 16x16 mix matrix. Using the DSP patchbays, the user can configure these channels to either analogue inputs/outputs or to channels on the digital audio expansion port.

Because of the fixed architecture, you do not need to assign DSP into the signal path, or worry about having enough DSP available to do the job. In **iDR**, we have given you the tools you need such as noise gates, compressors, delays, parametric EQ and look-ahead limiters, to start working with live audio straight away.

Adjustments are made in real time as there is no compiling to do, and our unique monitor buss allows you to listen to any point in the signal path. Copy and paste any DSP settings to quickly build up a design, save it as a configuration file, and use it as a template for other systems.

MIDI



iDR-8 is equipped with MIDI in/out/thru and custom MIDI commands can be output as presets and recalled on the **iDR**. This allows other audio devices such as samplers and processors to be controlled from the main unit.

For example, dynamic MIDI control from faders, rotary controls and keys in the **iDR** system could interface with a DMX controller, so that basic lighting control can be programmed into **iDR** and run from the **PL** series remote controllers.

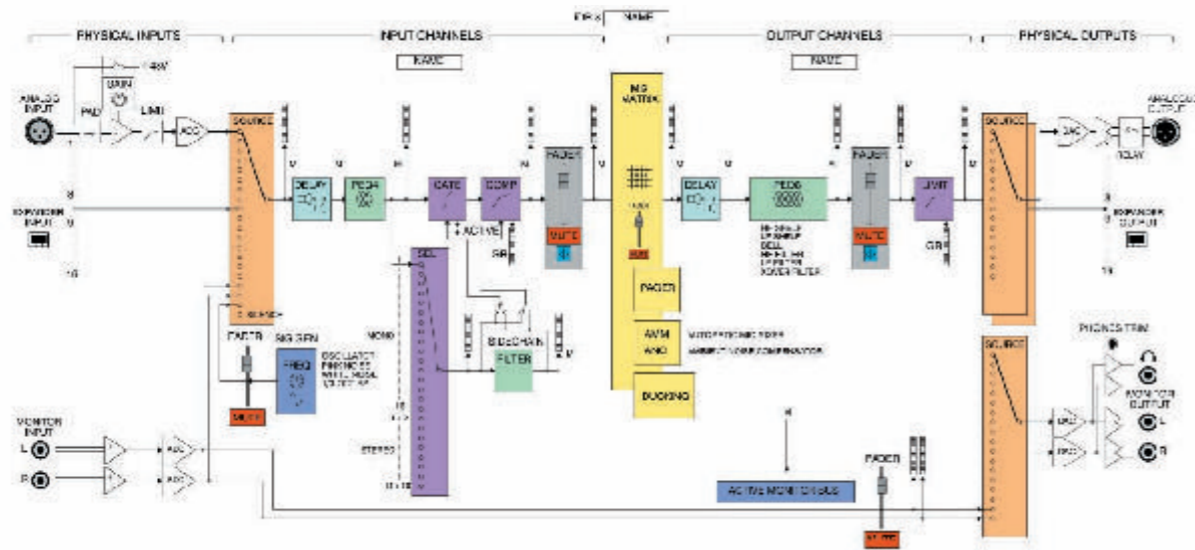

Features of iDR-8

- ★ iDR DSP system - 16 processing channels (inputs and outputs)
- ★ 8 analogue mic/line inputs on XLR3 with 48V phantom power
- ★ 8 analogue line outputs on XLR3
- ★ 2 line inputs on TRS jack
- ★ 2 line outputs on TRS jack
- ★ Digital audio expansion ports (8 channels in, 8 channels out)
- ★ Hot Plug'n'Play **PL** Series Remote controllers
- ★ High Quality Audio Signal Path and DSP processing
- ★ Headphone monitor with mouse and ripple-through capability
- ★ MIDI In/Out/Thru connections

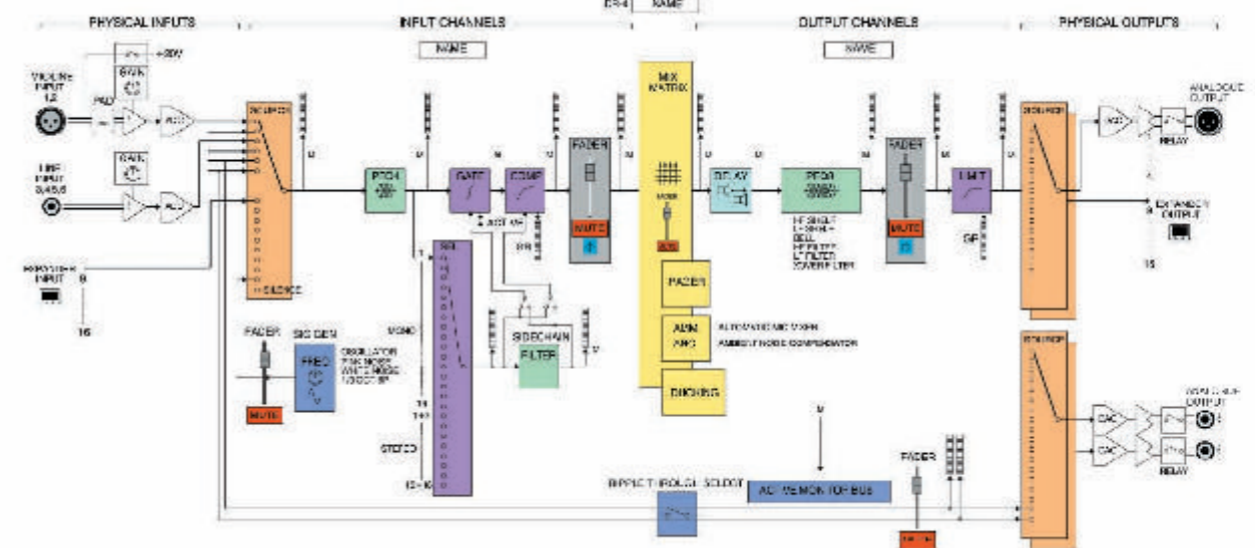

Features of iDR-4

- ★ iDR DSP system - 16 processing channels (inputs and outputs)
- ★ 2 analogue mic/line inputs on XLR with 20V phantom power
- ★ 4 analogue line inputs on TRS jack
- ★ 4 line outputs on XLR
- ★ 2 line outputs on TRS jack
- ★ Digital audio expansion port (8 channels in, 8 channels out)
- ★ Hot Plug'n'Play **PL** Series Remote controllers
- ★ High quality audio signal path and DSP processing
- ★ Monitor with mouse and ripple-through capability

iDR -In & -Out EXPANDERS



iDR-8 and iDR-4 can happily manage many complete systems with their existing input/output architecture standing alone. However, for larger systems, iDR-In and iDR-Out audio expander units are available, providing an additional 8 mic/line inputs on XLR and 8 line outputs (also on XLR) respectively. One or both expanders may be connected to a single iDR main unit.

These audio expanders convert the analogue audio to an 8 channel wide digital bus which feeds the main iDR unit, which can be up to 250 metres away, via CAT5 STP cable. iDR-In features high grade mic/line preamps with PC configured gain, pad and phantom power switching via DR-Link, and a built-in soft clip, while iDR-Out provides electronically balanced differential outputs. Both units have 8 front panel LEDs in addition to the 3 status indicators; these are 3-colour soft LEDs which can be assigned as audio meters, mute indicators or presets related indicators and are programmed in the usual way using the iDR System Manager software.

Example Combinations:

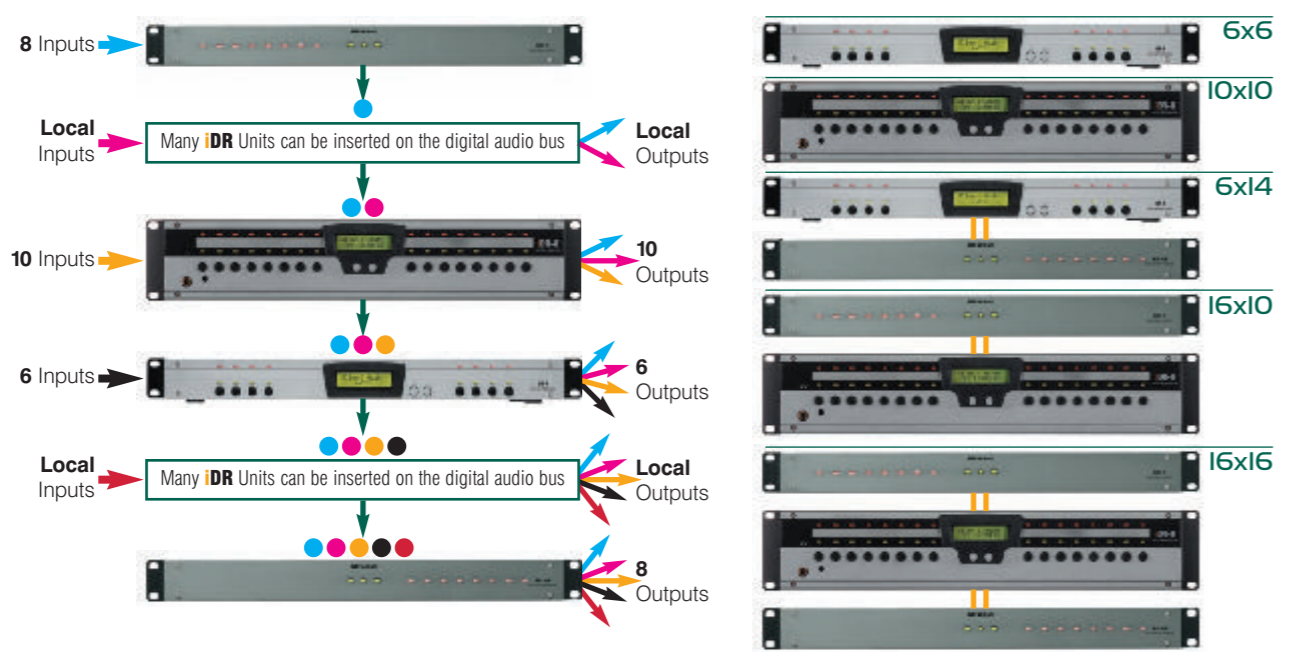

iDR CONTROL

A glance at the iDR back panel reveals the scope of iDR's control capabilities. iDR can communicate with many forms of equipment utilising industry standard communication protocols. For example, iDR-switch units, iDR-in and iDR-out expanders, third party controllers, PL Series 'intelligent' wall plates, MIDI show controllers, PCs, networks and modems. Up to 4 communications ports can be used at once - network and DR-link ports are always available, with two more selected from RS232, Sys-Net, MIDI and PL-Anet. Rear panel LEDs clearly indicate active ports for rapid communication status checking.

COMMUNICATIONS PORTS - iDR System

permanent protocols	connections	protocol type	uses
Network 			Network control and communication between computers, connection of iDR System Manager, PL-Designer and PL-Client. Connection to the internet for remote management and control purposes
DR-Link 			Links the iDR-In and iDR-Out audio expanders and iDR-Switch to the iDR units for logic control.
2 of 4 protocols selectable from software			
Sys-Net 			For third party controllers such as: AMX, Crestron, Cue, Audace and many more. Touch screens, Infr-red devices etc can be utilised with iDR.
RS232 			For connecting iDR to a phoneline for remote connection, management and operation (PPP = Point to Point Protocol).
RS232 Front (iDR-8 only) 			Used to update the system code in the unit
MIDI (iDR-8 only) 			For Remote Control using standard MIDI interfacing equipment. Custom remote controllers, show control, MIDI conversion equipment (e.g. MIDI to DMX) to control external equipment (e.g. lighting)
PL-Anet 			PL-Anet is an RS485-based protocol incorporating 20V phantom powering for the ALLEN&HEATH self detecting and self powered PL Range of remote controllers.

PL-Series

The **PL** series is the perfect interface between the **IDR** and the operators on site who don't need to understand the sound system - just control it. As the requirements grow at an installation, the control system can too! Start off with just the controls and display on the **IDR** unit then add wall mounted plates and hand-held remotes wherever they are needed using our CAT5 **PL-Anet** cabling system. **PL** remotes can simply daisy chain or use the **PL-Anet** hub for star wiring applications. LEDs in the system can be tri-colour status indicators [to indicate selected sources, or mutes] or they can become meters for any point in the signal flow. The LCD windows can easily be programmed to relay text information about the state of the system. You, as the designer, can customise these plug and play remotes to do exactly what the customer has been looking for. Each **PL** has its own simulator in **IDR** system manager software so you can design and demo the system offline as it will appear when the hardware is in place.

PL-3 & PL-4

PL-3 and **PL-4** wall plates have 4 or 2 programmable switches and 4 programmable tri-colour LEDs and are ideal for local operator control of the **IDR**-based audio system. They may be used, for example, for source selection for an output zone, or local volume control. The **PL-4** has, in addition, a rotary control with LED ladder and a built-in infra-red receiver - it can be operated at a distance using the **PL-5** handheld remote controller, allowing the operator to quickly and conveniently adjust the system from anywhere in the room. The control options can be different to those set on the **PL-4**.



PL-5

Examples of use: multiple source selection for an output zone. Local volume level, home cinema & AV system control (projector / lighting / amplifier control), and tamper-proof control.



PL-6

The **PL-6** is ideal as a remote mix controller - e.g. as a simple operator-controlled fader panel in an installed sound system, or as a personal musician's on-stage mix controller with in-ear monitors. It has 8 faders, 24 tri-colour LEDs and 16 soft switches which are all programmable via **IDR** System Manager. Other examples for use include as a basic lighting controller via MIDI/DMX, and the unit can be wall-mounted or flange-mounted into a table or wall.



PL-7

PL-7 is a stand-alone or surface mounted LCD panel, which enables remote display of status information and text messages which can be stored in the recallable memory settings. The **PL-7** can be embedded with **PL-3** or **PL-4** wall plates, allowing programmable control from a single unit. It can also be used for remote alarm/supervisor display.



PL-8

PL-8 is a 4 input, 4 output logic control panel mounted on a wall plate which can be connected to **PL-Anet**. It is designed to interface external systems such as alarm systems, juke boxes, room dividers, fader starts and lights at a convenient location.



PL-9

PL-9 is a 1U rack or desk mount hub which provides up to 7 individual connections to chains of **PL** devices, offering 'star wiring', simplifying wiring and eliminating the need for complex daisy-chaining. This also provides the benefit of longer cable runs and allows easier 'plug and play' of devices such as the **PL-6** and **PL-10**, and allows a larger number of **PL** controllers to be connected to a single **IDR** unit.

As the **PL-9** is the 'end of chain' on a **PL-Anet** branch, it offers greater flexibility by allowing **PL** wallplates to be plugged in and out easily - for example, a **PL-6** could just be plugged into a **PL-9** onstage, allowing local performer control, then removed after the event.

PL-10

The **PL-10** is similar to the **PL-6** - i.e. is a compact mixer interface, but has 8 rotary encoders, with LED ladder displays instead of faders, making it possible to mix live events within the **IDR** system. It's ideal for creating and controlling an output mix of cross-point groups. The **PL-10** can be assigned to read and adjust different mixes, as the LED bars indicate the levels managed by the **IDR** unit. The unit can be hand-held, or flange-mounted into a table or wall. As the **PL-10** has encoders rather than faders, it can respond to changes in levels made from other controllers.

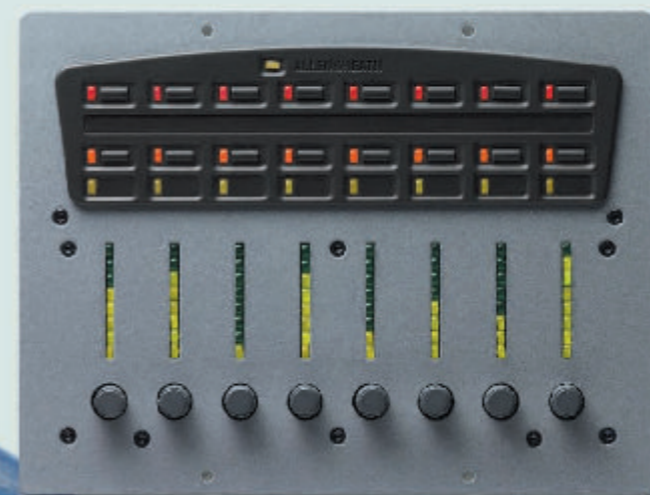

PL-Calculator

PL-Calculator is an Excel-based program which enables the installer to verify that a planned system with specified **PL** devices and inter-connect distances over **PL-Anet** conforms to the system specification. The program is bundled together with the **IDR** System Manager software.



PL-Anet Specification

Application	Network for ALLEN & HEATH intelligent remote controllers
Connection	RJ45, RS485 with +20V DC phantom power - terminator supplied
Protocol	Proprietary ALLEN & HEATH
Cable	CAT5 STP (Length table available from ALLEN & HEATH)





PL SOFTWARE

PL Designer and Client for Windows™

As well as being controlled by iDR System Manager, iDR systems can be controlled via a PC using 'PL Client', an interface which can be designed in 'PL Designer'.

PL Designer is used to create a custom interface which is opened using PL Client. The system architect can create a custom wall plate in PL Designer, providing system control tailored to the user's requirements. PL Designer lets the architect create a control layout from a selection of control types, such as switches, faders, mutes and meters, and positioned over a bitmap background. The architect can map functions from the iDR units into the Designer interface. The resulting PL Client panel, designed and customised according to the client's preference, can be installed on the client's PC. The result is the creation of customised, virtual wall plates. The PC can then be directly or network connected to the iDR for system control.

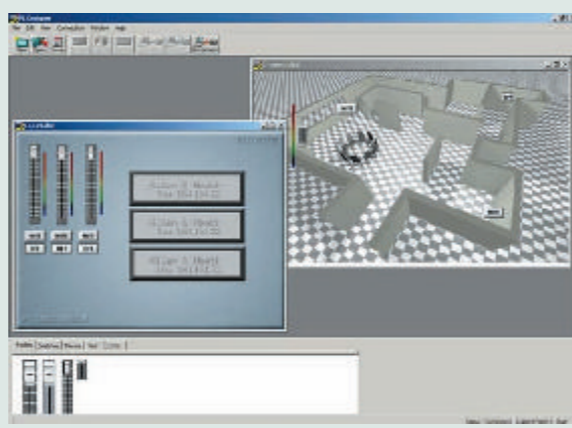

For example, the system architect could specify in PL Designer that: a venue manager could control source selects (e.g. CD, SAT-TV, DVD, etc), and levels of different zones on multiple floors using many iDR systems through one PL Client interface from the client's password-protected computer system. Further levels of access may also be added: for example, assistant managers of the venue may be provided with restricted access offering the ability for level control of their designated area only.

PL Client

PL Client, created with PL Designer, a tool within iDR System Manager, is the end user software, containing only the control elements in a .drd file with the design devices removed for tamperproof operation.

The PL Client software is demo-ware and time limited to 10 days. After that a key is required to run the software which is available from www.idrseries.com/pl_client.asp

For more information on setting up and configuring PL Designer/Client view the online documentation and help file contained in the iDR system manager software.

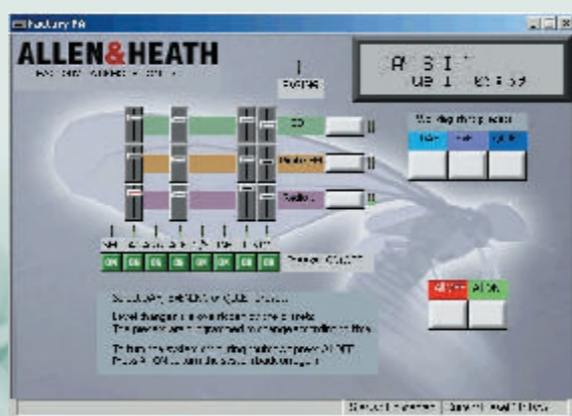

iDR SYSTEM MANAGER SPECIFICATIONS

Operating System iDR Unit Software, Internal Update using TCP/IP via system manager, RS232 via Hyperterminal	Compressor (x16) Threshold -48 to +18dBu Ratio Variable 1:1 to 1:infinite Knee Hard, Soft Makeup Gain 0 to +18dB Attack 300 s to 300ms, auto mode Release 100ms to 2s, auto mode Auto Modes Live, Music AGC, Vocal, Speech Display Response curve, gain reduction, in/out/sidechain meters Controls Compressor in/out, Sidechain in/out, auto on/off	AMM (x4) Automatic Mic Mixing NOM and ambient level average of all selected mics Ambient Level Sensing 4 to 20dB above ambient level Mic open threshold 0 to 5 seconds Hold time 1 to 6dB NOM Attenuation
System Configuration iDR System Manager software PC compatible running online or offline session. Includes all iDR and PL unit simulators for complete setup and test	Virtual Controllers PL-Designer for installer configured GUI PL-Client for restricted operator control	Level Control Input channels, output channels, monitor bus, signal generator Linear fader range Off to +5dB in 51 steps Controls Level, Mute, polarity reverse
Source Patchbay System Selectable physical source for each input and output channel Eliminates the need for a physical patchbay and signal splitters	Delay Input (x16) (iDR-3 only) Time 0 to 340ms per channel Units ms, metres, feet Temperature Global Adjust Coefficient for -20 to +40 degrees C	Fader Grouping Channel Faders can be assigned to be master faders (DCA) Fader Range Off to 0dB in 51 Steps Number of Input Fader Groups 8 Number of Output Fader Groups 8 Number of Crosspoint Fader Groups 16 Group naming up to 8 characters
PEQ Input (x16) PEQ Type 4 band fully parametric Band Type HF shelf, LF shelf, Bell, HPF, LPF, notch Range +/-15dB cut/boost, +/-12dB makeup gain Width, Q variable 0.5 to 6, constant Q on/off (notch width 10Hz to 100Hz) Display frequency response curve, meter Controls in/out, reset	Stereo Linking Adjacent channels can be linked for stereo operation Presents single channel strip Processing Linked Matrix routing Linked Stereo Metering	ANC (x4) Ambient Noise Compensator automatic controlled gain element in step with changes in background noise levels Ambient Level Metering Point I/P Source/Post-EQ/Post-Fade, O/P Post-Matrix/Pre-Fade/Post-Limiter, Channels 1-16 Ambient Level Gain Differential -18dB to +40dB Controlled Gain Element selects fader for control, I/P O/P I/P Group, O/P Group, Routing Gain, stereo operation Controlled Gain Operating Range min -59 to 5dB, max Controlled Gain Response Time rate dB per Second from 0.1 to 30dB Program Gap Metering Point I/P Source/Post-EQ/Post-Fade, O/P Post-Matrix/Pre-Fade/Post-Limiter, Channels 1-16 Program Gap Threshold -62dB to -20dB Program Gap Time 0s to 5s Display Level meters, Ambient Level Sampling Active LED Controls Enable On/Off
Gate (x16) Threshold -72 to +18dBu Depth 0 to -80dB Attack 20 s to 300ms Hold 50ms to 5s Release 50ms to 1s Display Level response curve, gate active, in, out, sidechain meters Controls Gate in/out, sidechain in/out	Metering Input Input Meters selectable source, post-EQ, post-dynamics, post-fade Output Output Meters selectable post matrix, pre-fade, post-fade, post-limiter Metering Points Input Source, Delay, EQ, Sidechain, Gate, Compressor, Fader Metering Points Outputs Delay, EQ, Fader, Limiter (can act as meters) green from 24dBu, yellow from 0dBu, red from +14dBu (4dB below clipping) Assignable LEDs Extensive on-screen display for all signal points in the signal path Select 1 of 4 meter bar display types	Ducking Type 16 channel multi priority selectable Priorities 1 (max) to 16 (min) Threshold -48 to +18dBu Depth 0 to -60dB Release 1 to 100dB/s Controls Ducker Enable On/Off
Sidechain Filter (x16) Source Switch into either compressor and/or gate EQ 1 Band, type and parameter control as PEQ	Mix Matrix Input / Output channel crosspoint (X/P) matrix Switch/gain matrix Matrix size 16 x 16 Fader range -38 to 0dB (-inf shutoff) Controls set, clear, mute, individual, row, column, all 16 freely assignable groups	Pager (x2) Type 2 independent configurable pagers Paging Activated from Front Panel, PL-Anet, MIDI, Sys-Net, iDR-Switch, networked iDR Zone Select Activated from Front Panel, PL-Anet, MIDI, Sys-Net, iDR-Switch, networked iDR Indicators Front Panel, PL-Anet, MIDI, Sys-Net, iDR-Switch, networked iDR Ducker Depth 0 to -40dB Controls page mic select, zone select, latching, press to talk, auto cancel
	Output Limiter (x16) Threshold -20 to +18dBu Attack 40us to 400ms Release 50ms to 1s Display level response curve, gain reduction, in, out, meters, time versus reduction histogram Controls in/out, fader	Audio Monitor Ripple through stereo audio monitor Source Select I/P 1-16 source, Delay, EQ, Sidechain, Gate, Compressor, Fader O/P 1-16 Delay, EQ, Fader, Limiter, Channel Outputs 1-16 (routed via output patchbay) Follows Mouse / Active Window
	Signal Generator Source variable frequency sine wave, white noise, pink noise, band pass pink noise Range (sine/band) 20Hz to 20 kHz Controls Fader, Mute	

GR Series

GR Series are analogue zone mixers for installation applications such as paging and background music systems in restaurants, retail outlets, leisure centres, clubs, theatres and offices. Designed to allow masses of flexibility and functionality at an affordable price, both models feature analogue inputs and outputs, plenty of routing options and a huge number of installer-set parameters, so that the system may be tailored for each installation task. Both units may be set up using front panel controls, and further control options are available using either jumper links or hidden front panel switches so that day-to-day operator controls are kept to a safe minimum. In a world of ever more complex software-based systems, the GR Series keeps it simple and keeps the system sounding perfect.



GR05

The GR05 is a 5-input, 4-output analogue zone mixer for sound installations requiring 2 mic and 3 stereo line to up to 4 mono or 2 stereo zones. Internal jumpers allow custom configuration protected for day-to-day operation by non-technical staff. Zone volume may be remotely controlled.



GR2

The GR2 is a 9-input, 4-output analogue zone mixer for sound installations requiring 6 mic/3 stereo line or 4 mic/4 stereo line to 1 stereo/1 mono zone and aux output. All settings are custom configurable from the front panel and are protected by a cover plate for day-to-day operation. Zone source selection, volume and more may be remotely controlled.



GR05 Applications

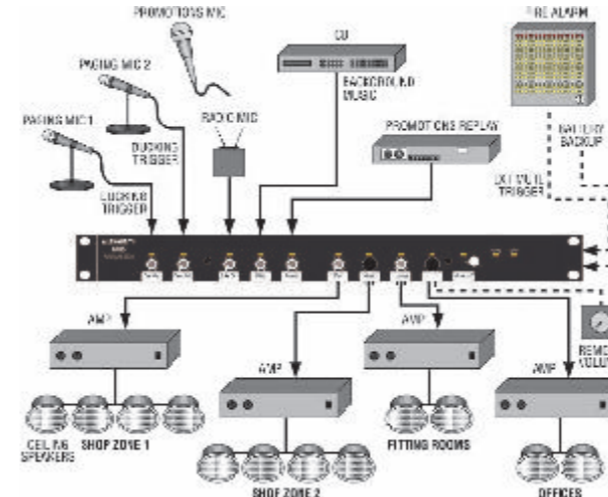

Retail

- 4 department zones
- 2 page mics duck music
- Roving mic for promotions
- BGM and pre-recorded sources
- Fire alarm interface
- Remote level control

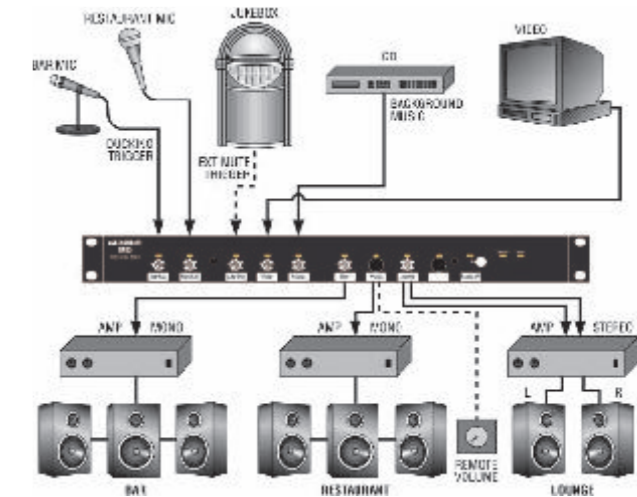

Bar/Restaurant

- 1 stereo, 2 mono zones
- 2 page mics duck music
- 3 stereo music sources
- Assignable routing to zones
- Jukebox mut BGM
- Mute music switch

GR2 Applications

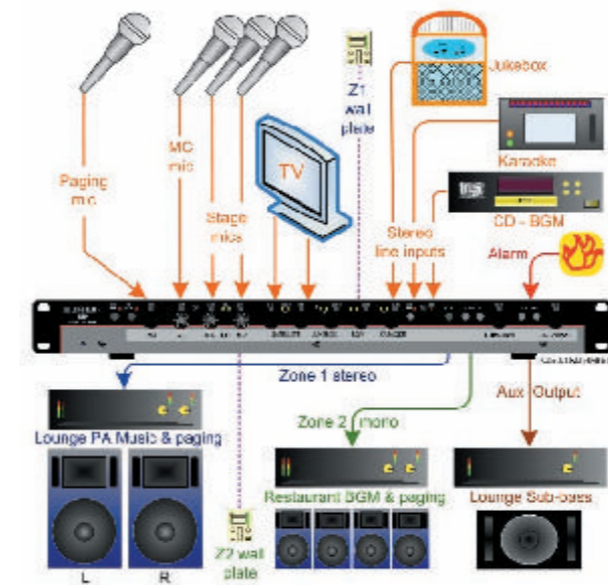

Entertainment Area

- Stereo and mono zones
- Filtered sub bass feed
- Page either zone
- 4 mics, page, karaoke, quiz
- 4 music sources with select
- Jukebox priority override

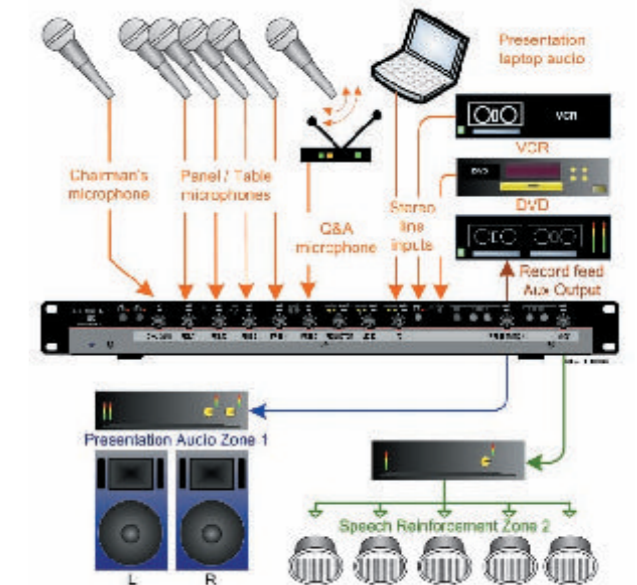

Conference

- Stereo presentation audio
- Mono speech reinforcement
- Aux output for recording
- 6 mics, 3 presentation sources
- Expander input for more mics
- Chairman priority override



The **GR05** is a 5-input, 4-output analogue zone mixer for sound installations requiring 2 mic and 3 stereo line to up to 4 mono or 2 stereo zones. Internal jumpers allow custom configuration protected for day-to-day operation by non-technical staff. Zone volume may be remotely controlled.

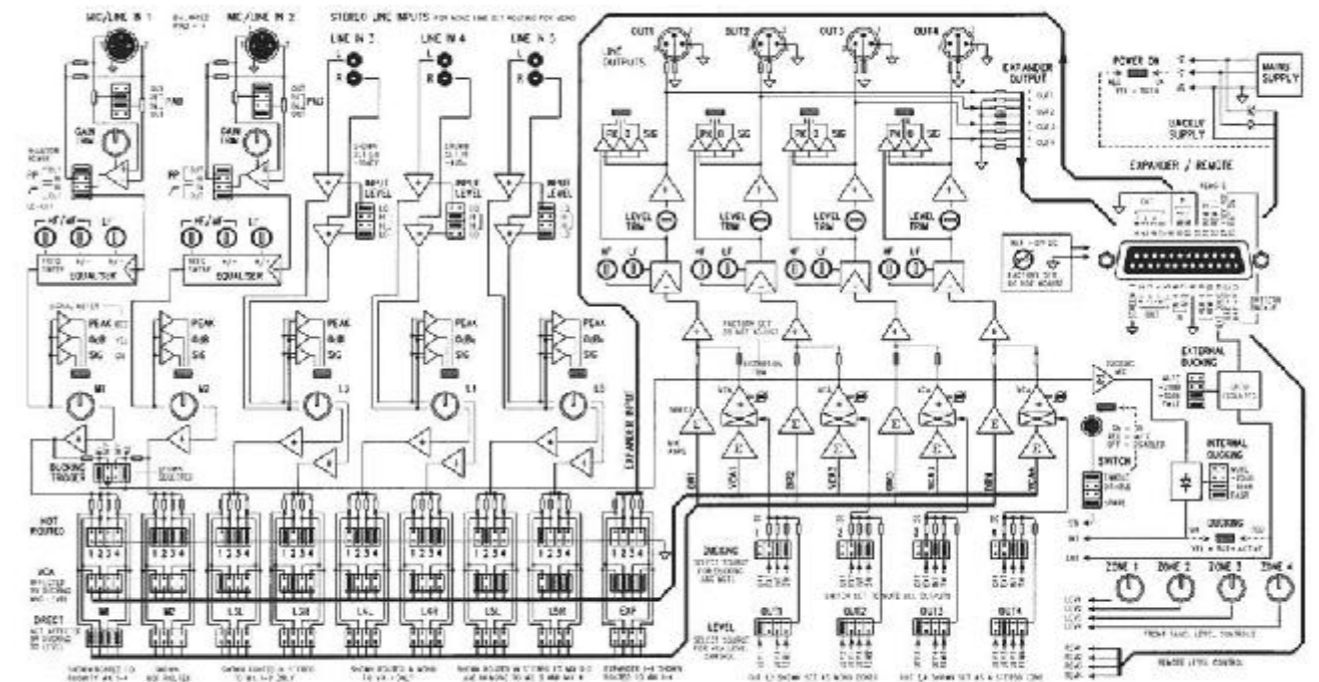

FEATURES

2 Microphone Inputs

The **GR05** is furnished with 2 balanced mic inputs on XLR, both of which have rear panel gain controls. Removal of the top panel allows access to internal jumper links, providing a 30dB attenuator pad, +15V phantom power and a high pass filter at 200Hz. Internal trimmers also provide 2-band EQ, hi-mid frequency with sweep and LF shelving. The front panel has 3-colour LED meters, and level controls for all routed outputs.

Stereo Inputs

3 RCA sockets are provided for stereo inputs, and internal jumper links allow access to -10dBV to +4dBu level matching. 3-colour LED meters and level controls are also provided for the stereo inputs on the front panel.

XLR Outputs

4 XLR connectors are provided for the outputs, which are internally configured by the jumper links for -10dBV to +4dBu. The outputs can be grouped and front panel level controls can be disabled using the internal. Internal trimmers also provide shelving EQ for HF and LF.

Other configurable functions include VCA control and outputs which can be assigned to front panel controls or alternatively, remote control operation. Zone muting is possible via a front panel switch and LED indicator.

Routing Matrix

All inputs can be routed to any combination of outputs direct, or via VCA control, so that the direct path is not affected by output level controls and ducking. Matrix assignment is achieved using internal jumper links.

Remote Control

VCA path remote control can be configured by the installer on internal jumpers. The expander option (using another **GR05** acting as slave to the main unit and connected by a 25-pin D connector) includes a remote DC input for each of the 4 outputs.

Ducking

The **GR05** allows ducking and muting of channels, and is configured either internally on jumpers or externally via an opto-isolated input for external trigger.

A status LED on the front panel is provided.

Expander / Remote

Additional mic & line inputs can be provided via another 'slave' **GR05** using the 25-pin D-type female connector.

Lock Out System

Input controls are always active; output levels controls may be disabled. All level controls may be set in 3 ways: 1) Knob fitted for operator control 2) knob removed for screwdriver preset 3) hole plugs (provided) fitted to lock out control.

PSU

Internal mains voltage PSU. DC backup input is provided. Status indicator.

Technical Specifications

0dBu = 0.775 Volts rms, +4dBu = 1.23V rms, 0dBV = 1 Volt rms, -10dBV = 316mV rms

MIC/LINE input

Balanced XLR, pin2 hot Pad out = >2k ohm, -58 to -22dBu
Pad in = >10k ohm, -28 to +8dBu
Phantom power +15V DC

STEREO input

Dual RCA phono >10k ohm, -10dBV or +4dBu

ZONE output

Z balanced XLR, pin2 hot <75 ohm, -10dBV to +4dBu trimmer

EXPANDER input

25-pin D female, unbalanced >10k ohm, 0dBu

EXPANDER output

25-pin D female, Z balanced <75 ohm, as set for zone out

Mic EQ

LF +/-12dB 70Hz shelf, M/HF peak/dip +/-14dB @ 300Hz to 6kHz

Output EQ

LF +/-12dB 70Hz shelf, HF +/-14dB 9kHz shelf

Maximum output

+20dBu into 2k ohm

Internal headroom

+20dB

Freq response

20Hz to 50kHz +/-1dB

THD+noise

<0.005% @ 1kHz +12dBu

Crosstalk

Better than -90dB shutoff, -80dB interchannel

Noise

Mic EIN -128dB referred to 150 ohm source
Line preamp -91dBu
Mix noise all routed <-86dBu

Remote level

Output VCA 0V = off, +10V DC = max
Remote DC reference +10V DC 5mA max

Ducking

Internal signal detect from mic 1 and/or 2
External trigger opto-isolated, switch to 0V
Selectable depth -10dB, -20dB, mute, speed fast, slow

Routing

Assignable 9x4x2 crosspoint matrix
OFF, DIRECT or VCA paths to each output

Signal meters

3-colour LED for each input and output
Green signal (-12dB)
Yellow 0dB
Red peak (+15dB)

Power supply

100 to 230V 47-63Hz AC, internally wired for country voltage 18VA max
DC backup +/-12V to 16V DC, 300mA

Mechanical specifications - Dimensions in mm

	Width	Height	Depth
Desktop	483	44/49	260
	(19")	(1.75")(1U)	(10.3")
Weight	4kg		(9lb)

GR2



The **GR2** is a new 1U rack or desk mount 9-input, 4-output, analogue zone mixer for demanding but budget-conscious installations requiring sound for live entertainment, paging, background music, conferences, presentations and a diverse range of modern architectural applications. The **GR2** offers the installer a host of front panel preset switches and trimmers to meet each special requirement. After installation, the settings are protected by a cover plate and unused controls may be blanked off to keep things simple for non-technical operators. There is a combination of XLR/RCA and screw terminal connectors for pre-wired or plug-and-play installation and extensive remote control capability using standard Cat5 cable.

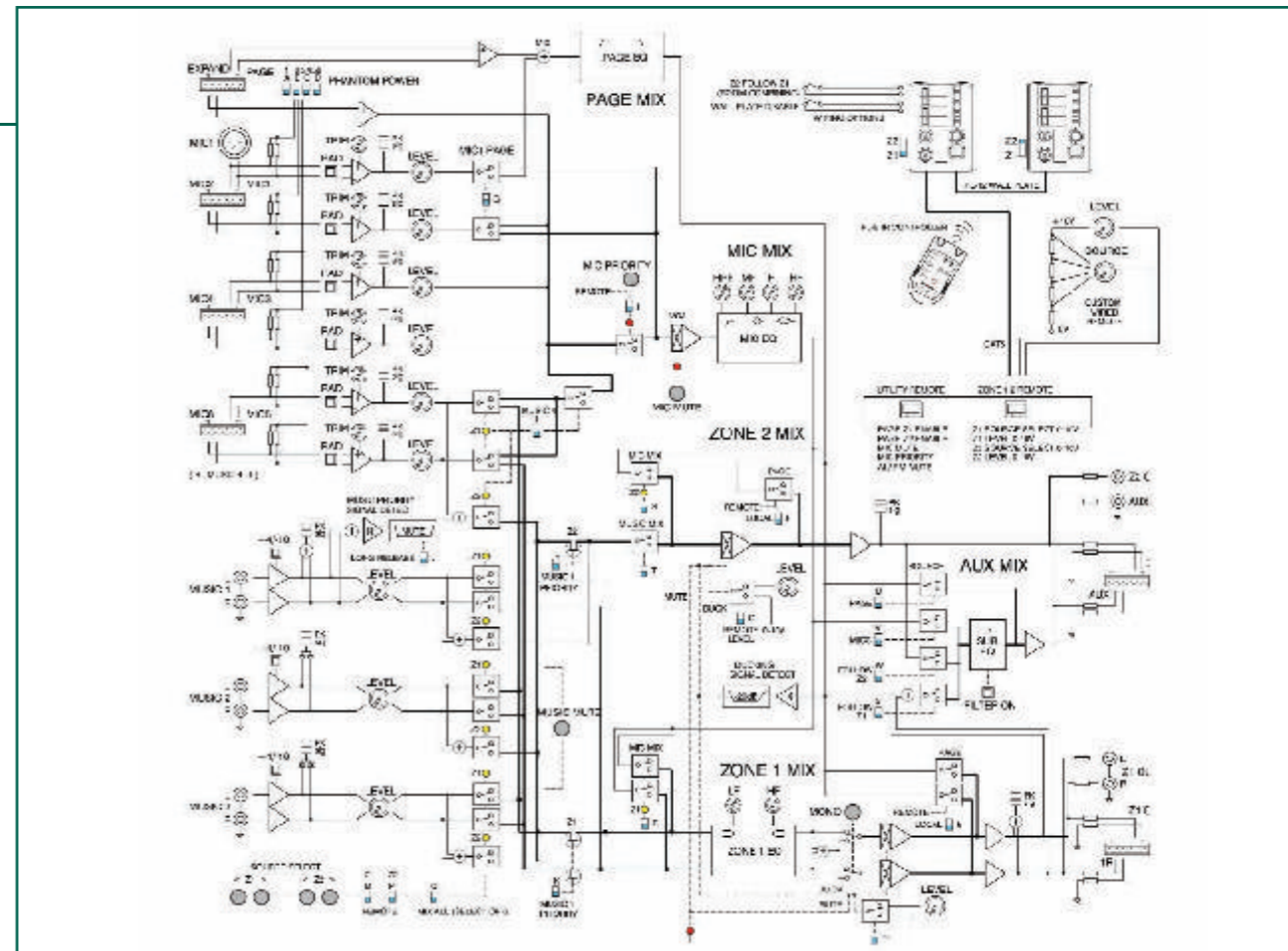

FEATURES

6 Mic/Line Inputs with EQ

Balanced inputs are provided on terminal blocks for convenient pre-wiring, with Mic 1 duplicated on XLR for quick plug-and-play. Each input has selectable +15V phantom power, protected mic/line pads and gain trimmers. There is a mic priority function for chairman or MC override, and a mic mute. The mic also has dedicated EQ with swept HPF, swept MF and shelving HF. An expander input allows more mics to be added to the mix.

3 (or 4) Stereo Music Inputs

Music channels are provided on RCA inputs with protected -10/+4 level settings. Mic/line 5/6 can be configured as a stereo input providing a 4 mic, 4 stereo line system. Inputs may be configured one at a time, or all together

Paging & Music Priority Override

GR2 offers a dedicated paging channel with tailored EQ for speech intelligibility. The source can be configured from Mic 1 and/or an external input or alarm message and the zone program is ducked when a page signal is detected. Music 1 may be configured as a priority input for jukebox and pre-recorded message override.

Mono & Stereo Zone Outputs

Outputs are available on both RCA and terminal blocks for pre-wiring or plug-and-play operation. Stereo Zone 1 may be configured for music only or music + mics, and mono Zone 2 can be configured for mics, music or music + mics. VCAs are provided for ducking, alarm override and remote level control. Zone 1 features a 2-band EQ and a mono switch.

Mono Aux Output

A versatile output for additional zone, mic expander, paging distribution, sub bass and more is provided on RCA and terminal block connectors. It is configurable as page out, mic mix, follow Zone 1 or Zone 2, and has a switchable 100Hz LPF for sub-bass feed.

Remote Control

The **GR2** uses standard RJ45 CAT5 cable for installation. 'Zone remote' allows remote level and source selection for both zones over a single cable. A 10V DC control input is provided for custom wired switches or potentiometer, third party interface or the **ALLEN&HEATH PL-12** wall plate. The **PL-5** hand-held IR controller is available for use with the **PL-12**. 'Utility remote' allows remote mic priority and mute switching, page selection and alarm override.

Configuration Protection

All settings are configured from the front panel. Preset dip switches are letter coded, and trimmers recessed for screwdriver access. A cover plate protects the settings and provides space for fitting a custom label. Any of the rotary knobs may be removed and hole plugs fitted as required.



PL Remote Controllers

PL-12 Wall Plate

Part of the **ALLEN&HEATH PL Series**, this intelligent wall plate provides remote level and source selection for the **GR2**. Two may be connected using a single CAT5 cable, one configured to Zone 1, the other to Zone 2. Additional custom wiring options are provided for Zone 2 follow Zone 1 room combiner switching and a wall plate disable function.



PL-5 IR Controller

This hand-held controller works with the **PL-12** IR sensor to duplicate the wall plate controls and add further functions including source mute and presets for favourite level and source selection settings.



Technical Specifications

0dBu = 0.775 Volts rms, +4dBu = 1.23V rms, 0dBV = 1 Volt rms, -10dBV = 316mV rms

MIC/LINE input

Balanced XLR (1), terminals Pad out = >2k ohm, -60 to -20dBu
 Pad in = >10k ohm, -30 to +10dBu
 Phantom power +15V DC

STEREO input

Dual RCA phono >10k ohm, -10dBV or +4dBu

ZONE output

RCA, Z balanced terminals <75 ohm, 0dBu, +20dBu max

EXPANDER input

Balanced terminals >10k ohm, 0dBu

PAGE input

Balanced terminals >10k ohm, 0dBu

Mic EQ

HPF 20-400Hz,
 MF peak/dip +/-12dB @ 200Hz to 5kHz,
 HF +/-12dB 10kHz shelf

Zone 1 EQ

LF +/-12dB 80Hz shelf,
 HF +/-14dB 10kHz shelf

Page EQ

HPF 150Hz, LPF 8kHz

Remote control

Level 0V = off +10V DC = max
 Source select 1=2V, 2=4V, 3=6V, 4=8V

Ducking

Signal detect threshold -20dB

Music priority

Signal detect threshold -20dB
 Release short = 2 sec, long = 12 sec

Signal meters

2-colour LED signal = -14dBu, peak = +14dBu

Power supply

100 to 230V 47-63Hz AC, universal mains input
 25VA max

Mechanical specifications - Dimensions in mm

1U rack or desk mount (removable rack ears)			
	Width	Height	Depth
Desktop	482mm (19")	44/49mm (1.75")	235mm (9.3")
Weight	3.6kg (8 lb)		